

CA168-S-NS06

Single-phase DIN-rail LoRaWAN Energy Meter

CA168-S-NS06 is an advanced & compact DIN-rail energy meter with split-type structure & Class 1 accuracy. Complying with STS standard, the meter is suitable for commercial & residential customers and has outstanding tamper detection features. It could make communication with the external Customer Interface Unit(CIU) by M-bus, PLC or RF, and communicate with the Data Concentrator via LoRaWAN for remote & centralized meter reading. Its installation requirements are also optional.



Main Features

- Double relays
- Multi-tariff
- DLMS/COSEM compliant
- STS prepayment
- 20-digit STS encryption
- 35mm DIN-rail installation
- Tamper detection & recording
- Remote & centralized reading by LoRaWAN communication
- MCU linking to CIU by M-bus/PLC/RF(optional)
- Slim-line & space-saving design
- Disconnecting on overload & no-credit condition
- Programmable warning of load limit & low credit
- Infrared port/RS485/virtual token carrier(optional)
- Surge protection against lightening & other line surges

Split-type Structure for Anti-tampering Protection

The meter consists of two parts, the MCU (Metering & Control Unit) and CIU (Customer Interface Unit), which could be linked via communication modes of M-bus, PLC or RF based on requirements. The CIU is installed inside the customer's home for inputting prepayment token and searching for information, while the MCU is normally installed in a meter enclosure away from the customer's home.

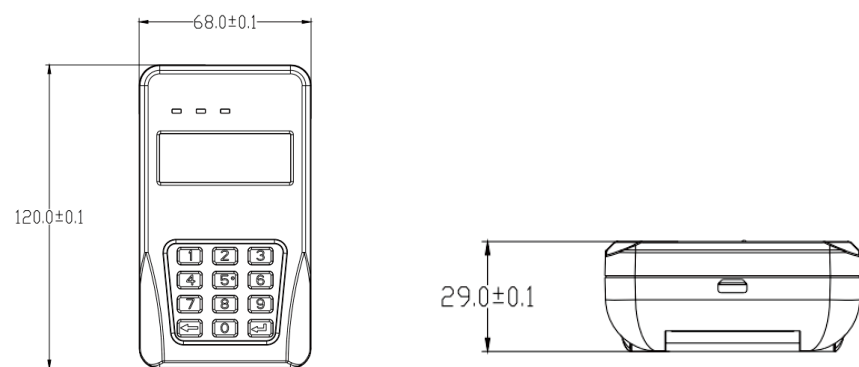

ELECTRICAL PARAMETERS

VOLTAGE	
Nominal voltage Un	230V
Limited voltage	70% ~ 120%Un
FREQUENCY	
Nominal frequency fn	50 ~ 60Hz
Tolerance	±5%
CURRENT	
Basic current(Ib)	5A
Maximum current(I _{max})	60A/80A
Starting current(I _{st})	20mA
Active energy constant	1000imp/kWh
MEASUREMENT ACCURACY	
Active energy as IEC62053-21	Class 1.0
POWER CONSUMPTION	
Voltage circuit	<2W <8VA
Current circuit	<1VA
TEMPERATURE RANGE	
Operation range	-25°C ~ +70°C
Storage range	-40°C ~ +85°C
INSULATION	
Insulation level	4kV rms 1min
Impulse withstand voltage	8kV 1.2/50 μs
Insulation system classification	Protection class II
ELECTRO MAGNETIC COMPATIBILITY	
ELECTROSTATIC DISCHARGES	
Contact discharge	8kV
Air discharge	15kV
ELECTROMAGNETIC RF FIELDS	
27MHz to 500MHz typical	10V/m
100kHz to 1GHz typical	30V/m
Fast transient burst test	4kV
MECHANICAL REQUIREMENTS	
Meter case protection class	IP54
Insulation system classification	Protection class II
Maximum cable size	8 mm

